

Quotation For: Patterns Derby
FAO: Stephen Smith
Quote Number: AMS ASN37
Date: 30 Mar 2017



WADKIN BURGSEEN | Compacta 4TR- Edge Banders



TECHNICAL SPECIFICATION

Max/Min Edge thickness	0,4-3 mm
Min/max board thickness	55-10 mm
Minimum board width	100 mm
Minimum board length	160 mm
Feeding speed	10m./min
Glue tank capacity	4 Lts
Air pressure	5-6 kg./cm ²
Pre-milling unit motor power	2 x 1,8 Kw
Milling tools speed r.p.m	12.000
End cutting motor power	2 x 0,37 Kw
Milling tools speed r.p.m	12.000
Edge trimmer motor power	2 x 0,75 Kw
Blades speed r.p.m	12.000
Corner Rounding trimming motor power	1 x 0,22 Kw
Milling tools speed r.p.m	12.000
Buffing motor power	2 x 0,37 Kw
Buffing brushes speed	1.400
Feeding motor power	2 HP
Installed total power	10 HP
Extraction Duct	2 X 75 mm
Machine sizes (mm.)	2800 x 900 x 1500
Weight	800 Kgs



Advanced Machinery Services Ltd, Skeffington Mill, Uppingham Road, Leicester LE7 9YE

Tel: 0844 844 | sales@advancedmachinery.co.uk | www.advancedmachinery.co.uk

Quotation For: Patterns Derby
FAO: Stephen Smith
Quote Number: AMS ASN37
Date: 30 Mar 2017

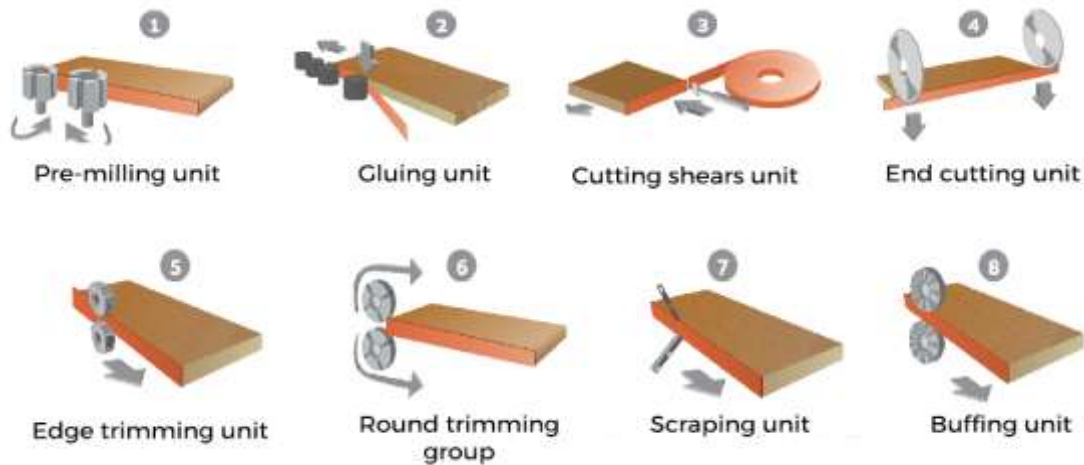

Control Panel

Easy handling, all electric functions on the same panel including the glue temperature control and Board thickness adjustment

Manual board thickness adjustment, simultaneously with the work groups, equipped with mechanical read out.



Pre-milling unit

Double pre-milling unit with HF 2,5 Hp. Motors, at 10.000 r.p.m, equipped with two milling tools of 80 mm. in M.D (Optional Diamond)

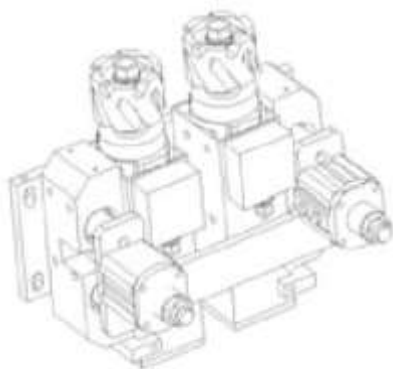

Quotation For: Patterns Derby
FAO: Stephen Smith
Quote Number: AMS ASN37
Date: 30 Mar 2017



Gluing Unit

Gluing roller with glue regulation and waste glue recovery. 4 steel rollers with pneumatic pressure



Cutting Shears Unit

Powerful cutting shears up to 3 mm edging thickness

End Trimming Unit

Double end trimming unit with HF independent motors, easy regulation type "copy", equipped with HM milling tools at 12.000 r.p.m getting an excellent finish in any material



Edge Trimming Unit

Double vertical end cutting unit, with HF motors. Movements through electro-pneumactical control



Quotation For: Patterns Derby
FAO: Stephen Smith
Quote Number: AMS ASN37
Date: 30 Mar 2017

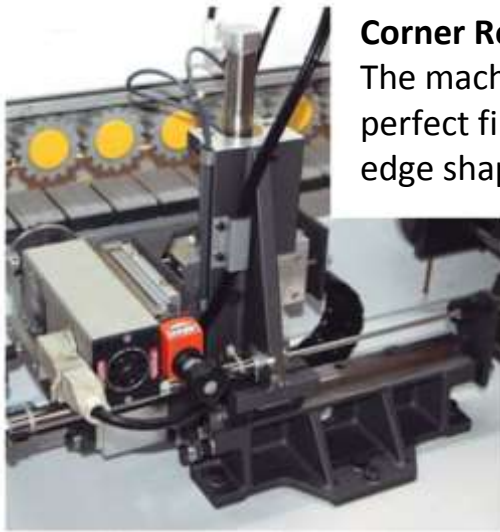

Corner Rounding Trimming Group

The machine incorporates a rounding trimming group that allows a perfect finish for edge corners with straight angles or with irregular edge shapes, on 40 mm as a maximum thickness piece.



Scraping Unit

Double group edge scraper, top and bottom, with air blowers.



Buffing Unit

Double buffing unit with independent motors, equipped with brushes of 180 mm. for perfect finishing



Quotation For: Patterns Derby
FAO: Stephen Smith
Quote Number: AMS ASN37
Date: 30 Mar 2017



The machine conforms to CE safety regulations

STANDARD PRICE EX WORKS

All prices are exclusive of VAT

Prices Quoted are firm for acceptance with 30 days

Delivery: Availability will be confirmed at the time of ordering.

Payment Terms: 30% deposit with order, 70% prior to dispatch from Leicester



Advanced Machinery Services Ltd, Skeffington Mill, Uppingham Road, Leicester LE7 9YE

Tel: 0844 844 | sales@advancedmachinery.co.uk | www.advancedmachinery.co.uk